

SAPHIR

450-500 SAT

HORIZONTAL

CENTRALIZED WASTE HANDLING

Our fully automated horizontal 45-50 ton balers in this line offer compact dimensions for environments where space is limited. Yet they are designed to meet the challenges by centralized waste handling, where large volumes of recyclable cardboard is produced. We provide well-proven technology for special demands! The automatic tying and continuous baling allows multi-shift operation.



Automatic solution



14 T/H

CAPACITY
CARDBOARD

600 K6

BALE WEIGHT (UP TO)
CARDBOARD

Optimal features

WELL PROVEN TECHNOLOGY

based on more than 50 years of experience

HIGH SPEED

fast throughput of the material

AUTO START

equipped with photocell start as standard

ADJUSTABLE BALE LENGTH

individual settings to meet your needs



Benefits for you

- + Enhanced productivity thanks to the automated process
- + Improved internal and external logistics
- + Safe and comfortable working environment
- + More profitable waste management and increased income from sales of recyclables

www.pressor.fr

SAPHIR

450-500 S AT

Smart fully automated solution

OPTIMIZED FOR:

PAPER

+ Paper sacks
+ Cardboard

PLASTIC

+ Shrink film
+ PET/ PEHD

METAL

+ Alu cans

CONTINUOUS FEEDING AND OUTPUT

A completely automated waste management solution designed for continuous infeed, automatic vertical strapping system with adjustable wire links, which enables you to yield optimal output.

A VARIETY OF INFEED OPTIONS

To fit the conditions in your environment, our horizontal balers offer a wide choice of infeed systems: manual, by bin, air-transport and conveyor belt.

Our balers can also easily be equipped with shredders, bottle presses, rufflers, strippers and different types of hoppers.

SAPHIR 450-500 S AT

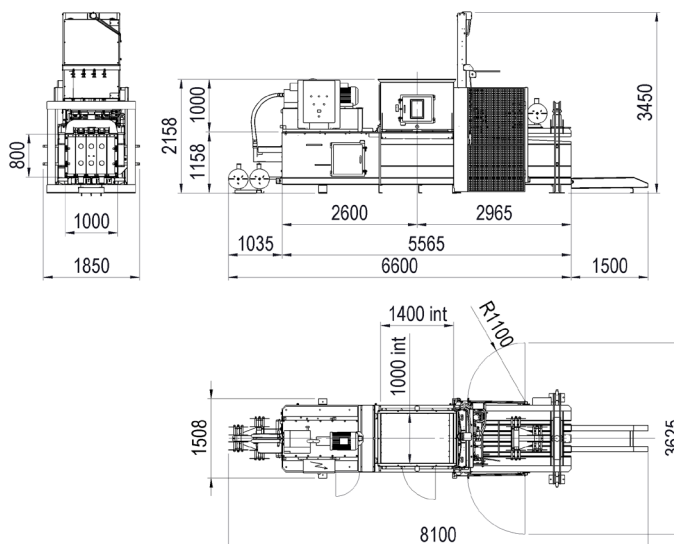

OPTIONS

+ BIN LIFTER

+ CONVEYOR BELT

+ COOLING & HEATING SYSTEMS

More special options on demand

DIMENSIONS & SPECIFICATIONS

TECHNICAL DATA

MODEL	450 AT	500 S AT
Machine dimensions (LxWxH mm without bale exit)	6600x1850x3450	6600x1850x3450
Feed opening (mm)	1400x1000	1400x1000
Infeed capacity (m³)	1.10	1.10
Press force (t)	45	50
Motor (kW / Hp)	7.5/10	15
Surface pressure (kg/cm²)	5.7	6.25
Cycles per minute	1.5-2	2.5
Channel section (mm)	1000x800	1000x800
Oil tank capacity (L)	200	400
Total machine weight (kg)	6500	7000
Theoretical output (m³/h)	75	165
Loading output (m³/h)	50	100
Automatic binding	4 wires Ø 3.2	4 wires Ø 3.2
Bale size (mm)	1000x800x	1000x800x
adjustable length (mm)	800-2150 mm	800-2150 mm
Bale weight cardboard (kg)	450-500 kg	400-600 kg
<i>depends on bale length</i>		



OPTION: CONVEYOR BELT



OPTION: BIN LIFTER

We reserve the right to make changes to specifications without prior notice. Bale weights are dependent upon material type.